



# Palazzani

**NORTH AMERICA**

# HIGH



# GREEN



# SAFE

**Aerial Spider Platforms**

## [palazzani-usa.com](http://palazzani-usa.com)

877-PALAZZANI | [sales@palazzani-usa.com](mailto:sales@palazzani-usa.com)

601 BRICKELL Key Dr Ste 700 - Miami, FL33131 US

# AMERICAN HEADQUARTERS OF Palazzani INDUSTRIE

Palazzani North America stands as a global leader in the design and manufacturing of the most complete and diverse range of **Spider Lifts and Cranes**, offering innovative solutions for every aerial work need.

## ABOUT US

Palazzani North America is the official branch of Palazzani Industrie, an Italian manufacturer of Spider Lifts with **90 years of history**. A determined and forward-looking company, Palazzani has continuously strengthened its position in an ever-changing market, expanding its presence globally while staying true to its heritage of quality and innovation.

We offer one of the widest and most advanced ranges of **Spider Lifts and Cranes** in the industry – from **53 ft to 170 ft** – providing safe, efficient, and reliable solutions for every height and application.

Palazzani North America is fully committed to representing the brand's core values: **innovation, dependability, and trustworthiness**, delivering **Italian engineering excellence** across the continent.

O.F.P. (Officina Fratelli Palazzani) began as a small family-run workshop dedicated to the production of agricultural equipment.

**1935**



**1954**

The company produced its first **earth-moving machines**, introducing a range of hydraulic wheeled loaders and cranes.



Where innovation meets reliability, Palazzani Spider Lifts stand as the ultimate solution for **safe, efficient, and versatile** work at height. Designed to perform everywhere, they embody the **strength, precision, and trust** that professionals rely on every day.

Thanks to the positive feedback from the market, the company expanded its operations and became a joint-stock company.

**1980**



Palazzani North America was founded to bring Palazzani Spider Lifts to the U.S. and Canadian markets, serving the rental sector and a wide range of professional industries.

**2024**



**1986**

The company launched its first Spider Aerial Platform, marking the beginning of a new era.



# INDUSTRY APPLICATIONS



## TREE CARE

At Palazzani North America, the arborist community represents a key part of our mission. We design and manufacture Spider Lifts using the highest-quality components and superior craftsmanship to ensure maximum safety, reliability, and productivity. Our commitment is to deliver solutions that empower tree care professionals to work efficiently and confidently, while maintaining the highest safety standards in the industry.

## RENTAL EQUIPMENT INDUSTRY

Our Spider Lifts combine versatility and reliability, making them ideal for the rental industry. Their compact design, lightweight build, and impressive reach allow easy access to tight spaces and challenging terrains.

Built with high-quality components and engineered for durability, they deliver consistent performance with minimal maintenance, helping our rental partners meet diverse customer needs and maximize return on investment.



## FACILITY AND INDUSTRY MAINTENANCE

Palazzani Spider Lifts are ideal for facility maintenance and industrial work, offering the flexibility and precision needed in confined or hard-to-reach areas. Built with high-quality materials and designed for tough environments, they provide safe, efficient access for maintenance, repairs, and inspections, helping to reduce downtime and improve operational efficiency.



...and more!

# AFTER-SALES SUPPORT

Palazzani North America is committed to delivering exceptional after-sales support, ensuring our customers achieve maximum productivity and satisfaction from their equipment.

We recognize that our relationship extends far beyond the initial purchase. Our dedicated service team provides prompt, expert assistance, minimizing downtime and keeping operations running smoothly. We believe that world-class service forms the foundation of lasting partnerships, and we strive to exceed expectations with every service call, technical consultation, and maintenance request.

Our commitment to superior product support includes a robust parts supply chain, regular maintenance programs, and ongoing technical training to keep our customers' equipment performing at peak efficiency.

We invest in state-of-the-art diagnostic tools and offer both on-site and remote support to address issues quickly. By actively listening to customer feedback, we continuously evolve our services to meet the unique needs of the industries we serve.

Our goal is to deliver not only high-quality equipment, but also a complete support experience that enables our customers to succeed in every project.



# TZJ 530 SPIDER LIFT



## LIGHTWEIGHT, COMPACT, AND HIGH-PERFORMANCE

The TZJ 530 Spider Lift is the ideal solution for professionals who need a lightweight, compact, and agile machine with exceptional performance for aerial work. It reaches up to **52.6 ft (16 m)** with an outreach of **24.7 ft (7.5 m)** and offers a **510 lb (230 kg)** basket capacity.

Equipped with a **telescopic double-articulated boom with jib** and electro-hydraulic proportional controls, the TZJ 530 ensures smooth, accurate movements. Operators can manage all functions from a single ground or platform control station, guaranteeing efficiency and safety during every operation.

Thanks to its **compact dimensions** and **extendable tracks** (2.6 - 3.1 ft), the TZJ 530 easily passes through standard doors, narrow gates, and corridors. This makes it ideal for urban settings, construction sites, and indoor applications where space is limited.

The extendable tracks and advanced stabilization system provide **maximum safety and stability**, even on uneven surfaces. Whether you're working on rough terrain or delicate flooring, the TZJ 530 adapts to your environment without compromise.

### TZJ 530/C



52 ft 6 in



24 ft 7 in



510 lb



360°



4 ft 7 in x  
2 ft 4 in



90°+90°



9 ft 7 in



27%



31%



1,86 mph



5324 lb



2923 lb



50.13 psf



69.34 psf

# TZJ SERIES

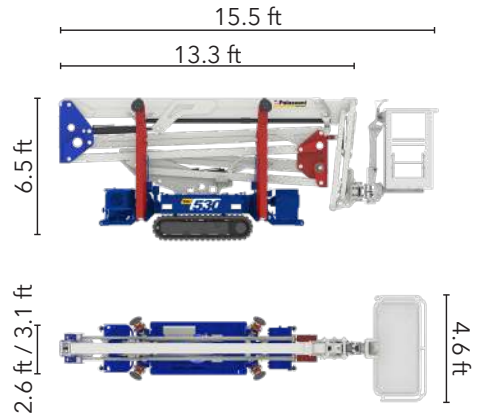
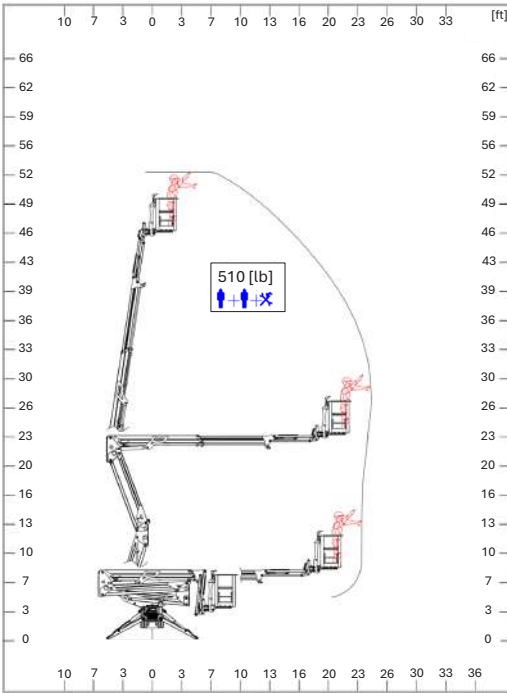

## STANDARD EQUIP.



BASKET ROTATION 90°+ 90°



ADDITIONAL AIR/WATER PIPES



PLASTIC PADS FOR OUTRIGGERS WITH STOP



RADIO CONTROL WITH MINI DISPLAY



CONTROL FOOT PEDAL ON THE CAGE



AUTOMATION PACK  
AUTOMATIC SET-UP  
"RETURN TO HOME" FUNCTION



**PETROL** Petrol Honda i-GX 390 engine 8,7 kW

**DIESEL** Diesel engine 10,6 kW

**ECO** Lithium battery LiFePO4 5,6 kWh

**ECO PRO** Lithium battery LiFePO4 11,2 kWh

# TZJ 590 SPIDER LIFT



## THE PERFECT BALANCE AMONG LIGHTNESS, STABILITY AND AGILITY

The TZJ 590 Spider Lift combines lightness, compactness, and agility to deliver maximum performance in any working condition. With a working height of 59.1 ft (18 m), an outreach of 26.3 ft (8 m), and a platform capacity of 510 lb (230 kg), it ensures excellent productivity and versatility for multiple aerial applications.

Lightweight and towable, the TZJ 590 easily passes through standard doors, gates, and corridors, making it ideal for indoor activities, maintenance, and urban environments. Its compact design and extendable rubber tracks (2.6 - 3.1 ft) allow smooth and safe movement even in confined spaces.

Equipped with electro-hydraulic controls and hydrostatic transmission, the TZJ 590 offers precise handling and excellent stability even on uneven or delicate surfaces. Its robust track system ensures perfect balance and operator confidence on every type of ground, from grass to pavement.

The telescopic double-articulated boom with jib and 360° turret rotation provide smooth and accurate positioning at any height. Safe, intuitive, and easy to use, the TZJ 590 is the perfect solution for rental fleets and professionals who need a compact, high-performance Spider Lift that's ready for every challenge.

### TZJ 590/C



59 ft



26 ft 3 in



510 lb



360°



4 ft 7 in x  
2 ft 4 in



90°+90°



9 ft 7 in



27%



31%



1,86 mph



5545 lb



3147 lb



56.18 psf



70.17 psf

# TZJ SERIES

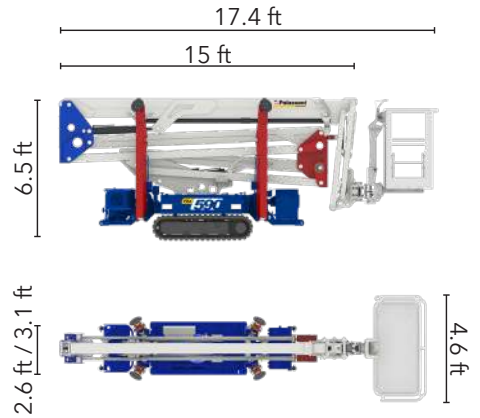
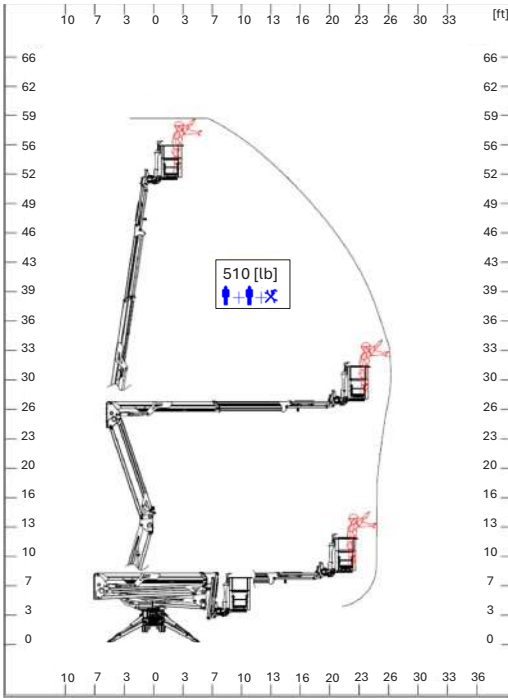

## STANDARD EQUIP.



**ADDITIONAL AIR/WATER PIPES**



**PLASTIC PADS FOR OUTRIGGERS WITH STOP**







**RADIO CONTROL WITH MINI DISPLAY**



**CONTROL FOOT PEDAL ON THE CAGE**



**AUTOMATION PACK  
 AUTOMATIC SET-UP  
 "RETURN TO HOME" FUNCTION**

-  **PETROL** Petrol Honda i-GX 390 engine 8,7 kW
-  **DIESEL** Diesel engine 10,6 kW
-  **ECO** Lithium battery LiFePO4 5,6 kWh
-  **ECO PRO** Lithium battery LiFePO4 11,2 kWh

# TZX 550 SPIDER LIFT



## COMPACT DIMENSIONS AND EXCEPTIONAL REACH

The TZX 550 Spider Lift offers unparalleled versatility for both indoor and outdoor use. It features a working height of 55.9 ft (16.8 m), a maximum outreach of 25.7 ft (7.8 m), and a minimum width of just 3.2 ft (985 mm), combining lightweight structure with compact dimensions to deliver high performance in tight spaces.

Built with aluminum frames with oversized sections and a low center of gravity, the TZX 550 provides excellent stability even in challenging aerial positions. All hydraulic pipes are routed inside the booms, ensuring maximum safety and minimal wear.

The TZX 550 is extremely light and compact, available on tracks or wheels, and equipped with fixed cage controls and ground remote controls for precise handling. Their innovative design ensures easy maneuverability in tight indoor and outdoor spaces while maintaining top performance.

Perfect for landscaping, facility maintenance, and industrial applications, the TZX 550 combines stability, reach, versatility, and reliability, enabling professionals to work efficiently and safely in a wide range of environments.

### TZX 550/C



55 ft 9 in



25 ft 7 in



440 lb



360°



4 ft 7 in x  
2 ft 4 in



90°+90°



10 ft 4 in



18%



31%



1,49 mph



4409 lb



2923 lb



39.03 psf



66.75 psf

# TZX SERIES

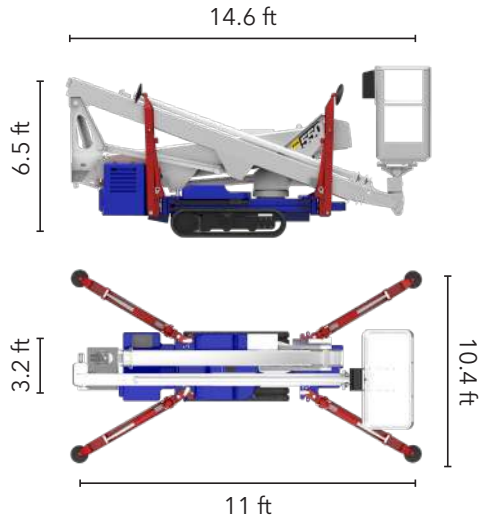
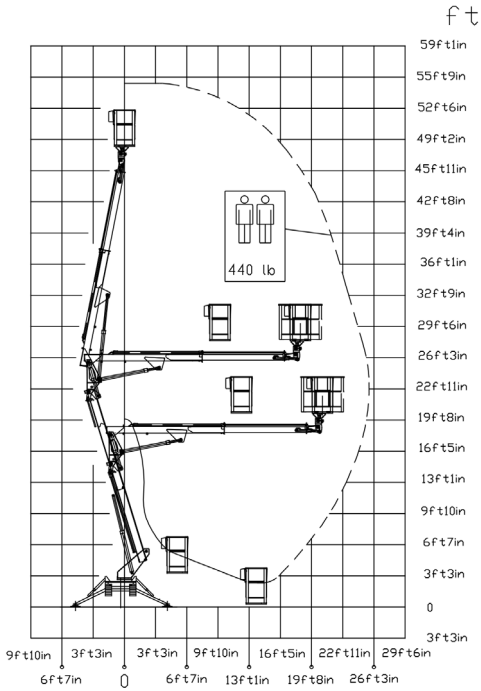

## STANDARD EQUIP.

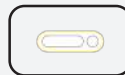

**NON-MARKING TRACKS**



**ADDITIONAL AIR/WATER PIPES**



**PROTECTION OF THE  
OUTRIGGERS' CYLINDER**



**RADIO CONTROL**



**PEDAL ON THE CAGE**



**RETURN TO HOME**



**PLASTIC PADS FOR  
OUTRIGGERS WITH STOP**



**BI-ENERGY** (Diesel + AC)  
**ECO** (AC + Battery)

# TZX 620 SPIDER LIFT



## PRECISE AND RELIABLE PERFORMANCE

The TZX 620 Spider Lift offers outstanding versatility with a working height of **62.4 ft (19 m)** and a maximum outreach of **27.1 ft (8.5 m)**, allowing two operators to work safely and efficiently in the basket with a capacity of **440 lb (230 kg)**. Its lightweight aluminum structure ensures easy transport and access through narrow spaces, making it ideal for both indoor and outdoor use.

Equipped with an **aluminum boom featuring two articulated and telescopic sections**, the TZX 620 delivers smooth and precise movements without restriction throughout its full working range. The **hydraulic control system** is simple, reliable, and intuitive, ensuring maximum operator confidence and control during every maneuver.

Set-up is quick and effortless thanks to the **automatic self-leveling system**, which guarantees perfect balance on any surface. The machine offers excellent stability even when driving on uneven ground or slopes, maintaining full safety and control in all conditions.

Perfect for landscaping, facility maintenance, and indoor-outdoor applications, the TZX 620 combines **precision, reliability, and agility**. Its robust design and easy handling make it the ideal solution for professionals seeking high performance and maximum stability in compact dimensions.

### TZX 620/C



62 ft 4 in



27 ft 11 in



440 lb



360°



4 ft 7 in x  
2 ft 4 in



90°+90°



12 ft



21%



23%



1,24 mph



5071 lb



3597 lb



36.44 psf



68.3 psf

# TZX SERIES

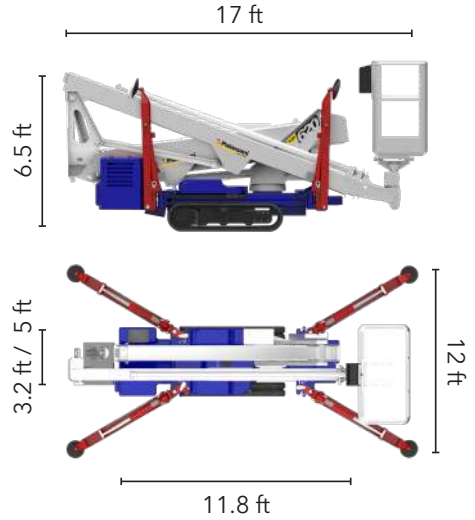
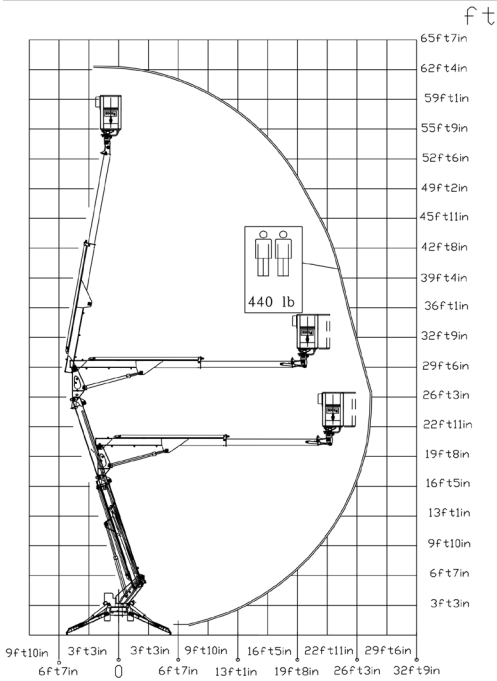

## STANDARD EQUIP.



NON-MARKING TRACKS



ADDITIONAL AIR/WATER PIPES



RADIO CONTROL



PEDAL ON THE CAGE



PLASTIC PADS FOR OUTRIGGERS WITH STOP



**BI-ENERGY** (Diesel + AC)  
**ECO** (AC + Battery)

# TZX 820 SPIDER LIFT



## OUTSTANDING HEIGHT AND VERSATILITY

The TZX 820 Spider Lift combines lightweight construction with extraordinary performance. It reaches a working height of **82 ft (25 m)**, an outreach of **34.9 ft (10.6 m)** and allows two operators in the basket without movement restrictions with a basket capacity of **550 lb (250 kg)**. Despite its compact size, it offers outstanding reach and flexibility, making it ideal for both indoor and outdoor applications.

Equipped with an aluminum boom featuring two articulated and telescopic sections, the TZX 820 ensures smooth, precise movements across its entire working range. Its innovative structure guarantees stability and control at every height, providing operators with maximum safety and confidence.

The TZX 820 offers double stabilization – wide and narrow – for quick, simple positioning even in confined spaces. The machine is equipped with no-marking tracks, allowing easy movement on delicate indoor floors as well as uneven outdoor terrain.

Perfect for gardening, landscaping, and maintenance work, the TZX 820 can also be equipped with a **550 lb (250 kg) hydraulic winch**, expanding its capabilities for light lifting operations. Compact, stable, and reliable, it represents the perfect balance between power, precision, and versatility.

### TZX 820/C



82 ft



34 ft 9 in



550 lb



360°



4 ft 7 in x  
2 ft 4 in



90°+90°



9.3 - 11.5 ft



19%



23%



1,49 mph



5864 lb



4384 lb



42.71 psf



77.47 psf

# TZX SERIES

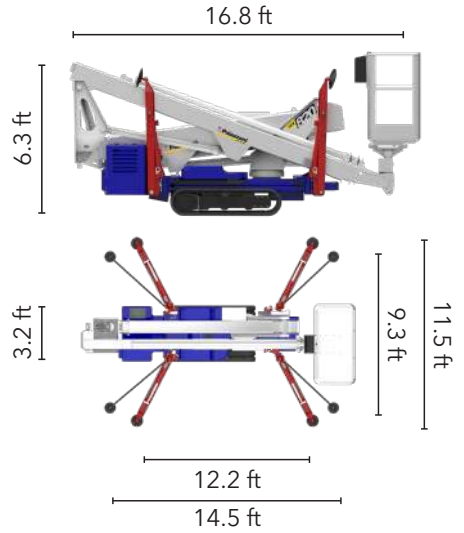
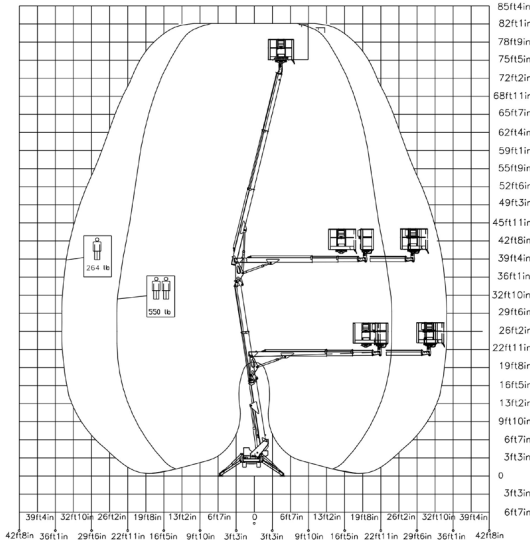

## STANDARD EQUIP.



ADDITIONAL AIR/WATER  
PIPES



PROTECTION OF THE  
OUTRIGGERS' CYLINDER



RADIO CONTROL



PEDAL ON THE CAGE



RETURN TO HOME



PLASTIC PADS FOR  
OUTRIGGERS WITH STOP



**BI-ENERGY** (Diesel + AC)  
**ECO** (AC + Battery)

# TSJ 82 SPIDER LIFT



## TO ACCESS AND SET-UP EVERYWHERE

The TSJ 82 Spider Lift delivers outstanding performance in a compact and lightweight design. With a working height of 82 ft (25 m), and exceptional outreach of 42.8 ft (12.8 m) and a basket capacity of 550 lb (250 kg) it offers operators maximum flexibility in a wide range of applications, both indoors and outdoors.

Thanks to its **adjustable tracks**—ranging from 4.3 to 3.2 ft (130-98 cm) and independently rotating stabilizers, the **TSJ 82** can access and set up even in the tightest or most uneven spaces. Its superior adaptability ensures safe operation on slopes, delicate surfaces, and confined environments.

The **multi-telescopic main boom** combined with an articulated jib ensures agile and precise movements at any height, with **zero tailswing** for enhanced maneuverability. All hydraulic hoses are routed inside the boom, offering **maximum protection** and reducing maintenance needs.

Designed for **maintenance, installation, and facility management**, the **TSJ 82** is engineered to deliver efficiency, safety, and precision in every task. Its **660° turret rotation** under any setup condition makes it a truly versatile solution for professionals who demand **reliability and performance** on every job.

### TSJ 82/C



82 ft



41 ft 12 in



550 lb



660°



4 ft 7 in x  
2 ft 4 in



90°+80°



8.6 - 16 ft



32%



36%



0,62 mph



8708 lb



5845 lb



34.19 psf



70.42 psf

# TSJ SERIES

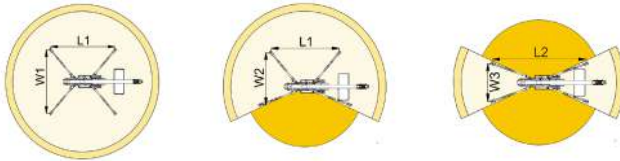
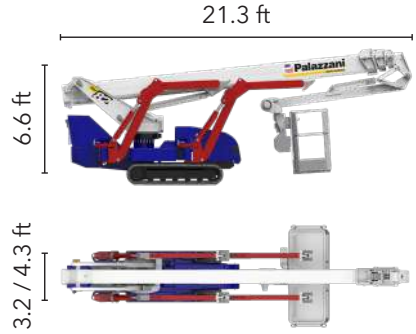
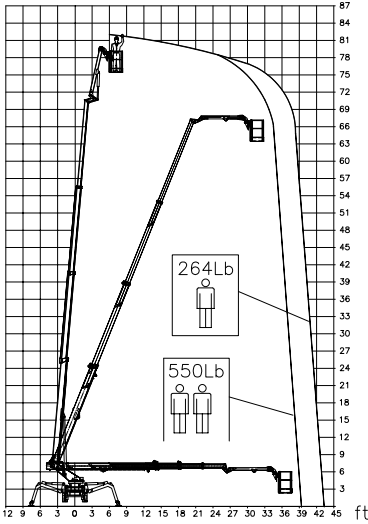

37 ft	41 ft	21.6 ft	L1	L2	W1	W2	W3
550 lb	264 lb	264/550 lb	16.3 ft	21.5 ft	15.9 ft	12.2 ft	8.6 ft

## STANDARD EQUIP.



NON-MARKING TRACKS



ADDITIONAL AIR/WATER PIPES



RADIO CONTROL



PEDAL ON THE CAGE



RETURN TO HOME



PLASTIC PADS FOR OUTRIGGERS WITH STOP



**BI-ENERGY** (Diesel + AC)  
**ECO** (AC + Battery)  
**HYBRID** (Diesel + AC + Battery)

# TSJ 98 SPIDER LIFT



## AGILITY THAT INSPIRES CONFIDENCE

The TSJ 98 Spider Lift represents the classic spirit of Palazzani engineering – a lightweight, compact, and versatile machine that never goes out of style. With a working height of **98.5 ft (30 m)**, an outreach of **42.7 ft (13 m)** and a basket capacity of **510 lb (230 kg)** it combines a traditional configuration with modern performance, making it the trusted choice for professionals across multiple industries.

Equipped with a five-section telescopic boom and a fixed jib, the **TSJ 98** ensures smooth and precise movements at all heights. The turret can rotate under any setup condition, while all hydraulic hoses are safely routed inside the boom, guaranteeing long-term durability and reduced maintenance.

Each outrigger can be positioned in **two different angles**, allowing the machine to **set up easily** in narrow or complex spaces. The **automatic self-leveling system** further simplifies operation, ensuring fast setup and secure positioning even on uneven terrain.

Designed for **construction, facility maintenance, and outdoor works**, the **TSJ 98** delivers a perfect balance between stability, reach, and portability. **Reliable, easy to transport, and safe to operate**, it remains one of the most versatile and enduring solutions in the Palazzani Spider Lift range.

### TSJ 98/C



98 ft 5 in



42 ft 7 in



510 lb



660°



5 ft 11 in x  
2 ft 4 in



90°+80°



9.4 - 15.8 ft



1100 lb\*



44%



42%



0,75 mph



10097 lb



6519 lb



40.52 psf



79.81 psf

# TSJ SERIES

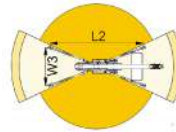
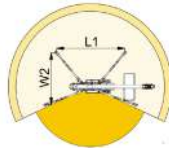
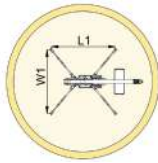
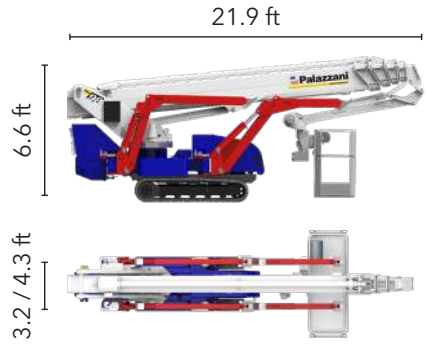
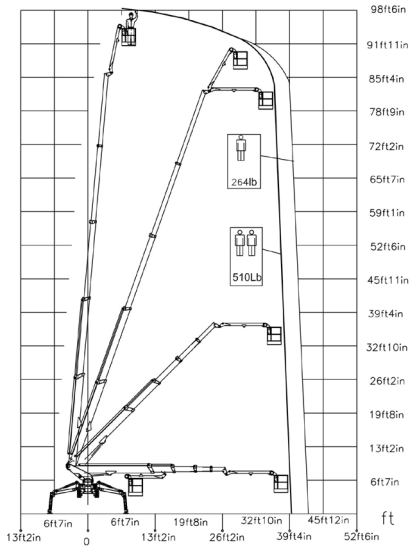

39.4 ft	42.7 ft	26.3 ft	L1	L2	W1	W2	W3
550 lb	264 lb	264/550 lb	16.1 ft	21.1 ft	15.8 ft	12.6 ft	9.4 ft

## STANDARD EQUIP.

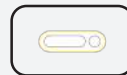

NON-MARKING TRACKS



ADDITIONAL AIR/WATER PIPES



TREE CUTTERS COVER KIT



RADIO CONTROL



PEDAL ON THE CAGE



RETURN TO HOME



PLASTIC PADS FOR OUTRIGGERS WITH STOP



**BI-ENERGY** (Diesel + AC)

**ECO** (AC + Battery)

**HYBRID** (Diesel + AC + Battery)

# TSJ 115 SPIDER LIFT



## POWER AND PRECISION AT EVERY HEIGHT

The TSJ 115 Spider Lift combines compact dimensions with exceptional performance, making it ideal for work in restricted or complex spaces. With a working height of 113.8 ft (35 m) an outreach of 49.3 ft (15 m) and a basket capacity of 510 lb (230 kg), it maintains a narrow and stowed profile both during driving and setup, ensuring easy access through gates, corridors, and confined job sites.

Engineered for simple and intuitive control, the TSJ 115 offers precise and fluid movements with zero tailswing, providing maximum safety even in tight environments. The telescopic sectioned boom and long fixed jib deliver outstanding outreach and positioning capabilities at every height.

Built with a robust structural design, the TSJ 115 guarantees excellent stability and operator comfort inside the cage. Its advanced undercarriage system ensures secure traction and fast transfers, even on steep or uneven terrain, maintaining reliability and balance at all times.

Perfectly suited for rental applications, restoration, and maintenance work, the TSJ 115 offers the ideal combination of performance, safety, and durability. It stands as the go-to solution for professionals who require high reach, dependable stability, and effortless mobility in one powerful machine.

### TSJ 115/C



113 ft 10 in



49 ft 3 in



510 lb



660°



5 ft 11 in x  
2 ft 4 in



90°+80°



8.9 - 17.3 ft



1100 lb\*



23%



36%



1,12 mph



15653 lb



10566 lb



50.91 psf



105.5 psf

# TSJ SERIES

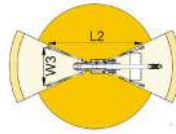
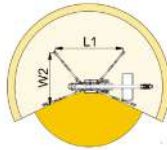
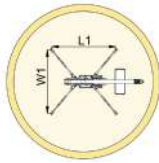
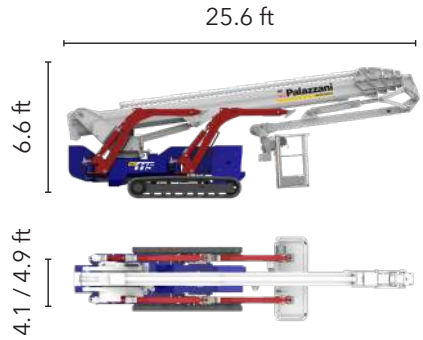
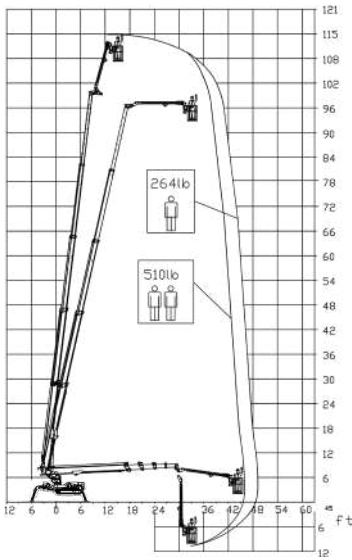

45.9 ft	49.3 ft	27.9 ft	L1	L2	W1	W2	W3
550 lb	264 lb	264/550 lb	18.2 ft	23.5 ft	17.3 ft	13 ft	8.9 ft

## STANDARD EQUIP.



NON-MARKING TRACKS



ADDITIONAL AIR/WATER PIPES



TREE CUTTERS COVER KIT



RADIO CONTROL



PEDAL ON THE CAGE



RETURN TO HOME



PLASTIC PADS FOR OUTRIGGERS WITH STOP



**BI-ENERGY** (Diesel + AC)

**ECO** (AC + Battery)

**HYBRID** (Diesel + AC + Battery)

# TSJ 127 SPIDER LIFT



## STRENGTH THAT DELIVERS STABILITY

The TSJ 127 Spider Lift offers the perfect balance of strength, stability, and versatility. With a working height of 127.9 ft (39 m), an outreach of 54.2 ft (16.5 m) and a basket capacity of 510 lb (230 kg) it provides exceptional performance in both indoor and outdoor applications. Its compact dimensions and lightweight design make it easy to transport and position, even in challenging environments.

The automatic leveling system ensures a fast and simple setup, allowing operators to begin work in just minutes. Whether on flat surfaces or steep terrain, the TSJ 127 adapts effortlessly, maintaining a secure and stable aerial position at all times.

Built with a reinforced frame, the TSJ 127 guarantees outstanding stability and comfort in the cage, even at full height. The machine ensures steady movements and smooth transfers, maintaining optimal traction and safety even on strong slopes or uneven ground.

The TSJ 127 adapts perfectly to different work environments – from landscaping to indoor and outdoor maintenance. Durable, reliable, and easy to use, it represents the strength that provides stability, true to Palazzani's engineering heritage.

### TSJ 127/C



127 ft 11 in



49 ft 3 in



510 lb



660°



7 ft 10 in x  
2 ft 4 in



90°+80°



9.6 - 15.5 ft



1100 lb\*



18%



40%



1,12 mph



17549 lb



11465 lb



71.3 psf



89.74 psf

# TSJ SERIES

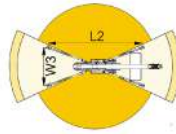
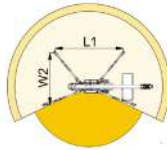
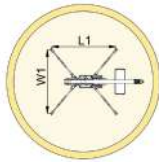
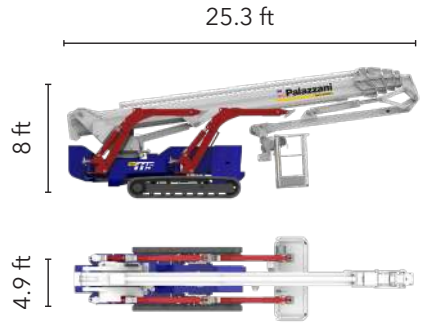
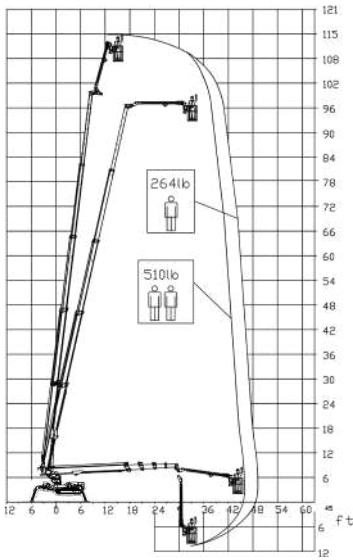

32.9 ft	54.1 ft	27.9 ft	L1	L2	W1	W2	W3
550 lb	264 lb	264/550 lb	16.3 ft	20.4 ft	15.4 ft	12.5 ft	9.6 ft

## STANDARD EQUIP.

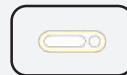

NON-MARKING TRACKS



ADDITIONAL AIR/WATER PIPES



TREE CUTTERS COVER KIT



RADIO CONTROL



PEDAL ON THE CAGE



RETURN TO HOME



PLASTIC PADS FOR OUTRIGGERS WITH STOP



**BI-ENERGY** (Diesel + AC)

**ECO** (AC + Battery)

**HYBRID** (Diesel + AC + Battery)

# TZ 108+ SPIDER LIFT



## INNOVATION THAT ELEVATES PERFORMANCE

The TZ 108+ Spider Lift delivers the perfect combination of lightness, precision, and versatility. With a working height of 104.9 ft (33 m), an outreach of 53.8 ft (16.4 m) and a basket capacity of 550 lb (250 kg), it guarantees exceptional performance in a wide variety of applications – from construction sites to indoor and outdoor maintenance.

Equipped with an innovative double pantograph boom, the TZ 108+ ensures smooth and perfectly balanced vertical movements. This unique design provides maximum flexibility in aerial operations, allowing operators to maintain consistent outreach even in confined or irregular spaces.

Thanks to its independent stabilizers featuring a minimalist design and multiple setup configurations, the TZ 108+ can be easily positioned on uneven ground or in restricted areas. The compact footprint allows for effortless access and setup, ensuring safety and efficiency on every job.

Engineered for both construction and maintenance tasks, the TZ 108+ stands out for its stability, ease of operation, and durability. Its lightweight design, combined with advanced engineering solutions, makes it one of the most innovative and dependable Spider Lifts in its class.

### TZ 108+/C



104 ft 12 in



53 ft 9 in



550 lb



360°



5 ft 11 in x  
2 ft 4 in



90°+90°



10.3 - 16.1 ft



18%



32%



1,49 mph



15873 lb



11016 lb



64.8 psf



119.29 psf

# TZ SERIES

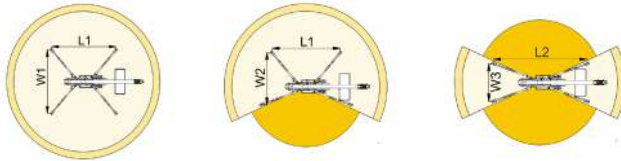
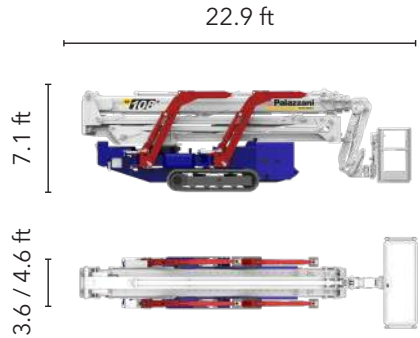
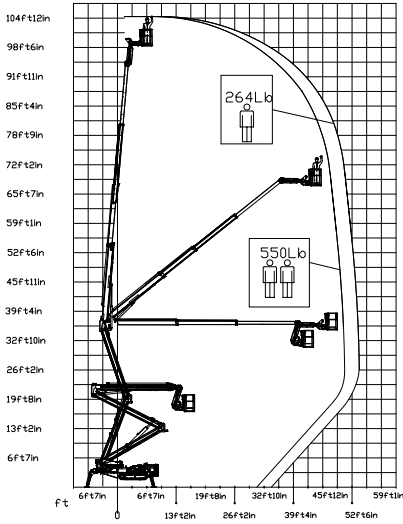

50.6 ft	53.9 ft	31.2 ft	L1	L2	W1	W2	W3
550 lb	264 lb	264/550 lb	15.6 ft	20.3 ft	16.1 ft	13.2 ft	10.3 ft

## STANDARD EQUIP.

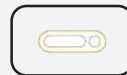

NON-MARKING TRACKS



ADDITIONAL AIR/WATER PIPES



TREE CUTTERS COVER KIT



RADIO CONTROL



PEDAL ON THE CAGE



INTER-PHONIC COMMUNICATION SYSTEM



PLASTIC PADS FOR OUTRIGGERS WITH STOP



**BI-ENERGY** (Diesel + AC)

**ECO** (AC + Battery)

**HYBRID** (Diesel + AC + Battery)

# XTJ 105 SPIDER LIFT



## TECHNOLOGY THAT DELIVERS PURE PERFORMANCE

The XTJ 105 Spider Lift offers unmatched flexibility and precision, reaching a working height of 104.9 ft (32 m), an outreach of 46.9 ft (14.3 m) and a basket capacity of 730 lb (330 kg). Compact in transport and powerful in operation, it ensures excellent performance in every environment, from construction sites to indoor and outdoor maintenance.

Engineered for high productivity, the XTJ 105 maintains impressive function speeds even when operating in electric mode, combining sustainability with power. Its **compact overall dimensions** allow easy access through tight passages and quick positioning on any job site.

Equipped with a **telescopic flying jib** and **660° turret rotation**, the XTJ 105 ensures total freedom of movement and precision control at every height. These advanced features allow operators to reach difficult points with ease while maintaining full **stability and safety**.

The XTJ 105 features a **multi-position automatic leveling system**, enabling quick and easy setup both in narrow spaces and on steep slopes. Its adaptive stabilization ensures **perfect balance** and operator confidence in all working conditions, making it a true benchmark for 360° performance.

### XTJ 105/C



104 ft 12 in



46 ft 11 in



730 lb\*



660°



5 ft 11 in x  
2 ft 4 in



90°+80°



9.3 - 15.6 ft



16%



32%



1,86 mph



13095 lb



7868 lb



50.84 psf



99.76 psf

# XTJ SERIES

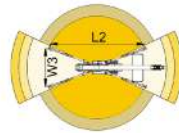
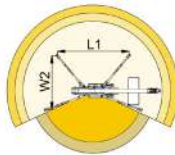
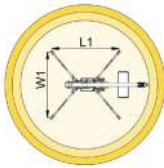
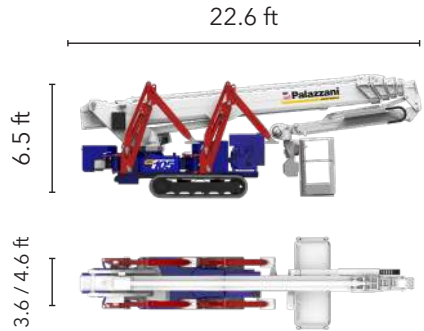
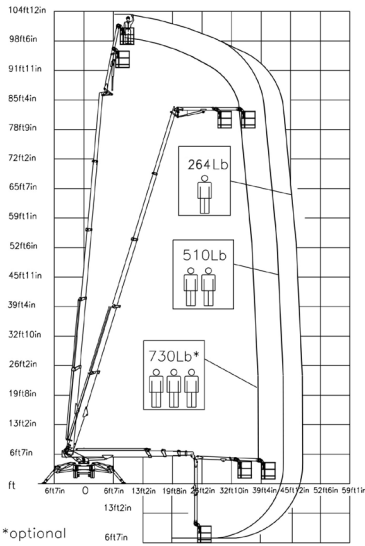

38.4 ft	43.7 ft	46.9 ft	27.6 ft	32.9 ft	L1	L2	W1	W2	W3
730 lb*	510 lb	264 lb	730 lb*	264/510 lb	16.9 ft	21.2 ft	15.7 ft	12.5 ft	9.3 ft

## STANDARD EQUIP.

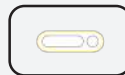

NON-MARKING TRACKS



ADDITIONAL AIR/WATER PIPES

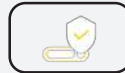

TREE CUTTERS COVER KIT



RADIO CONTROL



PEDAL ON THE CAGE



RETURN TO HOME



PLASTIC PADS FOR OUTRIGGERS WITH STOP



**BI-ENERGY** (Diesel + AC)  
**ECO** (AC + Battery)

# XTJ 121+ SPIDER LIFT



## THE SMART POWER OF VERSATILITY

The XTJ 121+ Spider Lift stands out for its compact dimensions and exceptional maneuverability. It offers a working height of 121.4 ft (37 m), a maximum outreach of 49.2 ft (15 m), and a basket capacity of 730 lb (330 kg). Despite its narrow frame, it guarantees stable performance and precise movements in every situation – even in confined spaces – thanks to its zero tailswing design.

Each stabilizer offers two positioning options, enabling **quick and flexible setup** on uneven or restricted surfaces. The entire process is fully automatic, reducing operator effort and ensuring perfect leveling at all times, even on demanding job sites.

Equipped with the innovative **automatic “Area Manager”** system, the XTJ 121+ continuously monitors the working envelope and adjusts the operating range for **maximum safety and efficiency**. This intelligent system ensures optimal outreach under all configurations, supporting operators in every condition.

With its **660° turret rotation** under any setup condition, the XTJ 121+ offers complete working flexibility for a wide variety of professional tasks – from **construction and building maintenance** to **telecommunication installations**. It's the ideal choice for rental fleets and operators seeking reliability, technology, and performance in one compact solution.

### XTJ 121+/C



121 ft 4 in



49 ft 3 in



730 lb\*



660°



5 ft 11 in x  
2 ft 4 in



90°+80°



8.8 - 17.3 ft



1100 lb\*



23%



36%



1,55 mph



16733 lb



12364 lb



54.42 psf



112.78 psf

# XTJ SERIES

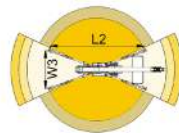
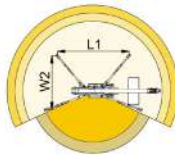
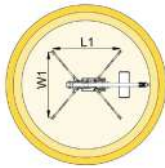
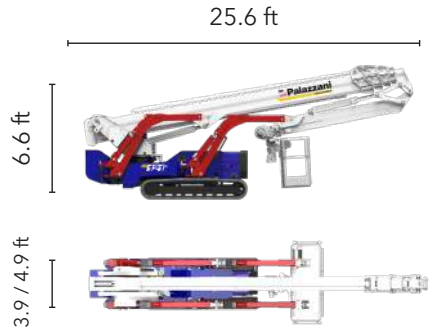
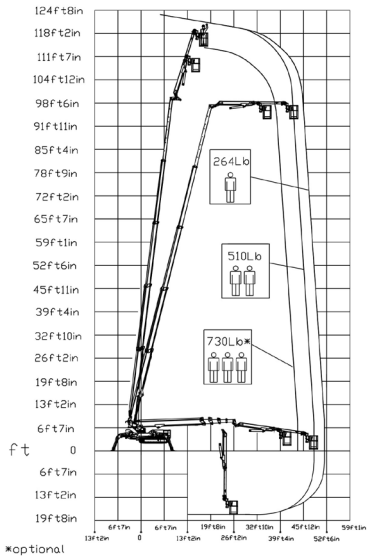

38.8 ft	46.3 ft	49.2 ft	23.9 ft	31.2 ft	L1	L2	W1	W2	W3
730 lb*	510 lb	264 lb	730 lb*	264/510 lb	18.1 ft	23.5 ft	17.3 ft	12.6 ft	8.8 ft

## STANDARD EQUIP.

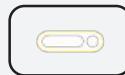

NON-MARKING TRACKS



ADDITIONAL AIR/WATER PIPES



TREE CUTTERS COVER KIT



RADIO CONTROL



PEDAL ON THE CAGE



RETURN TO HOME



PLASTIC PADS FOR OUTRIGGERS WITH STOP



**BI-ENERGY** (Diesel + AC)

**ECO** (AC + Battery)

**HYBRID** (Diesel + AC + Battery)

# XTJ 140+ SPIDER LIFT



## THE FUTURE OF CONTROL

The XTJ 140+ Spider Lift reaches a working height of 141 ft (43 m) with a maximum outreach of 59 ft (18 m) and a basket capacity of 730 lb (330 kg). Despite its impressive performance, it remains compact, narrow, and lightweight, ensuring easy access and setup even in confined or complex environments. Its zero tailswing guarantees safe and precise operation, making it a benchmark in its category for both indoor and outdoor applications.

The **automatic self-leveling system** allows quick and effortless setup on any terrain. Each outrigger can rotate independently in two different positions, enabling the XTJ 140+ to adapt seamlessly to narrow spaces or uneven ground. Stability, speed, and operator comfort are ensured in every working condition.

Equipped with an innovative **“Area Manager” safety system**, the XTJ 140+ continuously monitors the working envelope to optimize outreach and prevent operator errors. This intelligent interface represents a new level of human-machine interaction, ensuring **total control, efficiency, and safety** in every maneuver.

With a **660° turret rotation** under any setup condition, the XTJ 140+ offers unmatched flexibility and productivity. Ideal for **construction sites, restoration work, and telecommunications**, it’s the perfect solution for **rental fleets** and demanding professionals who require advanced technology, performance, and reliability from their equipment.

### XTJ 140+/C



141 ft 1 in



59 ft 1 in



730 lb\*



660°



7 ft 10 in x  
2 ft 4 in



90°+80°



11.9 - 17.1 ft



1100 lb\*



23%



38%



1,24 mph



24582 lb



16861 lb



73.2 psf



112.69 psf

# XTJ SERIES

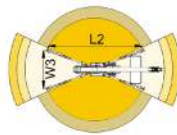
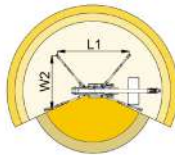
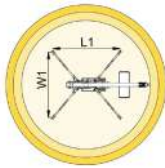
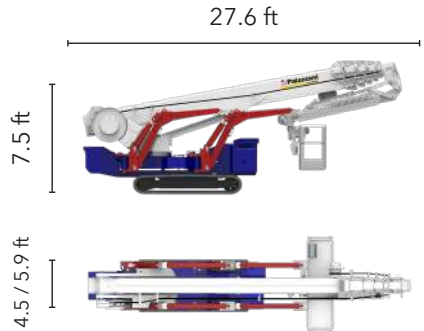
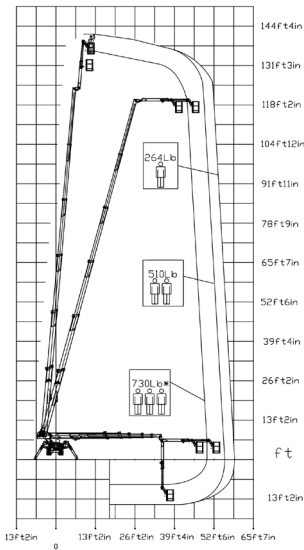

49.9 ft	55.8 ft	59 ft	38.7 ft	44.3 ft	L1	L2	W1	W2	W3
730 lb*	510 lb	264 lb	730 lb*	264/510 lb	19.5 ft	23.3 ft	17.1 ft	14.6 ft	11.9 ft

## STANDARD EQUIP.



NON-MARKING TRACKS



ADDITIONAL AIR/WATER PIPES



TREE CUTTERS COVER KIT



RADIO CONTROL



PEDAL ON THE CAGE



RETURN TO HOME



PLASTIC PADS FOR OUTRIGGERS WITH STOP



**BI-ENERGY** (Diesel + AC)  
**ECO** (AC + Battery)

# XTJ 170+ SPIDER LIFT



## THE GIANT OF PERFORMANCE

The XTJ 170+ Spider Lift is the true colossus of the Palazzani range, offering a working height of **170.6 ft (52 m)**, a maximum outreach of **63.9 ft (19.5 m)**, and a basket capacity of up to **880 lb (400 kg)**. Despite its impressive dimensions, it remains remarkably agile and balanced, delivering precise and responsive performance at every height. Designed to handle the most demanding applications, it stands as the ultimate solution for professionals who require extraordinary reach, capacity, and control.

Thanks to the advanced **"Area Manager"** system, the XTJ 170+ automatically adjusts outreach and performance parameters based on the stabilization mode and load (120 / 230 / 400 kg). This intelligent system allows operators to maximize **efficiency and safety in every setup**, providing seamless transitions between work areas.

Engineered for both **power and precision**, the XTJ 170+ ensures fluid, accurate maneuvers at any height. Its **660° turret rotation**, combined with fast hydraulic response, allows operators to cover wide working areas with minimal repositioning – making it perfect for dynamic work environments.

Ideal for **telecommunications, construction, restoration, and maintenance** – both indoor and outdoor – the XTJ 170+ represents the pinnacle of stability, versatility, and safety. It's the preferred choice for **rental companies** and industry professionals who demand top-tier performance from their aerial platforms.

### XTJ 170+/C



170 ft 7 in



63 ft 12 in



880 lb\*



660°



7 ft 10 in x  
2 ft 4 in



90°+80°



13.6 - 16.9 ft



2160 lb\*



16%



42%



1,24 mph



33025 lb



21357 lb



93.11 psf



145.61 psf

# XTJ SERIES

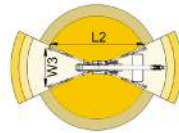
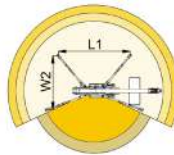
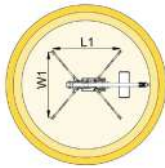
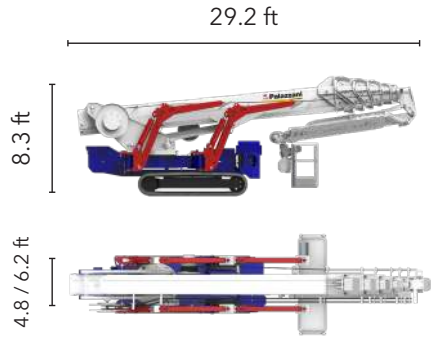
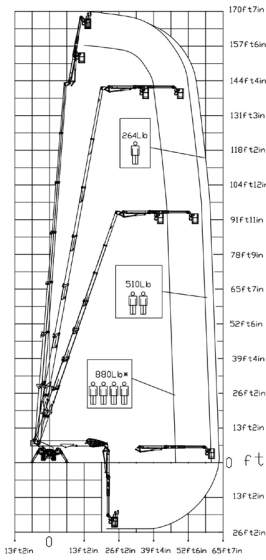

47.6 ft	60.7 ft	63.9 ft	41 ft	54.1 ft	L1	L2	W1	W2	W3
730 lb*	510 lb	264 lb	730 lb*	264/510 lb	21.2 ft	23.6 ft	16.9 ft	15.3 ft	13.6 ft

## STANDARD EQUIP.

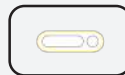

NON-MARKING TRACKS



ADDITIONAL AIR/WATER PIPES

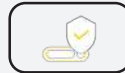

TREE CUTTERS COVER KIT



RADIO CONTROL



PEDAL ON THE CAGE



RETURN TO HOME



PLASTIC PADS FOR OUTRIGGERS WITH STOP



**BI-ENERGY** (Diesel + AC)  
**ECO** (AC + Battery)



# INNOVATION & TECHNOLOGY BEHIND EVERY SPIDER LIFT

**ITALIAN ENGINEERING. AMERICAN PERFORMANCE.**

## **ENGINEERING EXCELLENCE**

Palazzani's design philosophy is rooted in **strength, lightness, and efficiency**. Each structure uses aircraft-grade **aluminum and STRENX steel** to deliver the highest strength-to-weight ratio in the industry. Our booms are **hand-assembled** and robot-welded for perfect geometry and long-term durability.

## **SMART CONTROL SYSTEMS**

Precision control defines every Palazzani Spider Lift. The **Area Manager safety system** constantly analyzes outreach and load, ensuring **smooth, safe movement** in any configuration. Features like **Return-to-Home, multi-position automatic leveling, and radio control** provide intuitive operation and maximum productivity.

## **ECO & HYBRID POWER**

Palazzani pioneered **LiFePO<sub>2</sub> lithium-battery** and hybrid powertrains long before they became industry standards. **Quiet, clean, and powerful**, our lifts operate indoors **without emissions** and outdoors with full performance. **Dual-power** systems switch seamlessly between electric and diesel, reducing fuel consumption and extending runtime.

## **SAFETY BY DESIGN**

Safety is engineered, not added. Palazzani integrates **redundant hydraulics, load-sensing valves, non-marking tracks, and automatic outrigger monitoring** to protect operators and equipment in every condition. From **stability sensors to emergency descent controls**, our Spider Lifts meet or exceed global safety standards.

***"Trusted by Professionals. Driven by Innovation."***  
*Palazzani North America – Reaching New Heights Together.*

# PARTNERS IN PERFORMANCE

## BUILDING A STRONGER NETWORK – TOGETHER

Palazzani North America is more than a manufacturer – we're a partner in your success. Through training, parts support, and dealer collaboration, we help rental companies, contractors, and service professionals reach new heights with confidence.

## OUR GROWING NORTH AMERICAN PRESENCE

From our U.S. headquarters in Miami, Palazzani North America supports a rapidly expanding dealer network across the United States and Canada. Local parts inventory, factory-trained technicians, and on-site demo support ensure customers receive world-class service wherever they work.

- 24-hour response time commitment
- Stocked U.S. parts warehouse (Miami HQ)
- Remote diagnostics and field support
- Hands-on training & certification programs

## BECOME A PALAZZANI DEALER

Join a network dedicated to **quality, safety, and growth**. We work closely with dealers and rental partners to **build long-term value** through exclusive programs, co-branding opportunities, and priority support.

- Exclusive territory opportunities
- Flexible floor plan and financing options
- Dedicated sales & marketing resources
- Access to demo units and training events

## CONTACT US TO BECOME A PALAZZANI DEALER:

877-PALAZZANI | [sales@palazzani-usa.com](mailto:sales@palazzani-usa.com) | [palazzani-usa.com](http://palazzani-usa.com)

## TOGETHER WE ELEVATE

Palazzani North America is committed to innovation, dependability, and service – values that fuel our growth and our partners' success. Whether you're lifting into a canopy or onto a tower, Palazzani provides the power and precision to get there safely.





## TREE CARE

- Safer than traditional “climbing”
- Backyard accessibility
- Lower insurance costs
- Increased productivity

## RENTAL INDUSTRY

- Access solutions for every job
- Higher ROI than traditional aerial boom lifts
- Single and double door accessibility
- Expand and diversify your fleet

## INDUSTRIAL APPLICATIONS

- Atrium maintenance & cleaning
- Window cleaning made easy
- Lightweight for special floor loads
- Multiple power options for indoor use

**FINANCE  
YOUR NEW  
PALAZZANI  
SPIDER LIFT!**

Fast. Flexible. Hassle-free.